

# Product Data Sheet

## MSKT Guardrail End Terminal

Last Updated: March 2024

Containment Level	MASH TL3
Impact Condition	2270 kg pick-up truck, 100km/h
System Length	14.3 m
Post Spacing	1.905 m centres
Quantity of Posts	8 off
Point of Need	Post #3
Maximum Allowable Flare Offset	600 mm
System Mass	555 kg
Containment Level	MASH TL2
Impact Condition	2270 kg pick-up truck, 70km/h
System Length	9.5 m
Post Spacing	1.905 m centres
Quantity of Posts	5 off
Point of Need	Post #3
Maximum Allowable Flare Offset	300 mm
System Mass	410 kg
System Height	800 mm
System Width	435 mm
System Finish	Hot dip galvanized



# Product Data Sheet

## MSKT Guardrail End Terminal

### TL3 Configuration

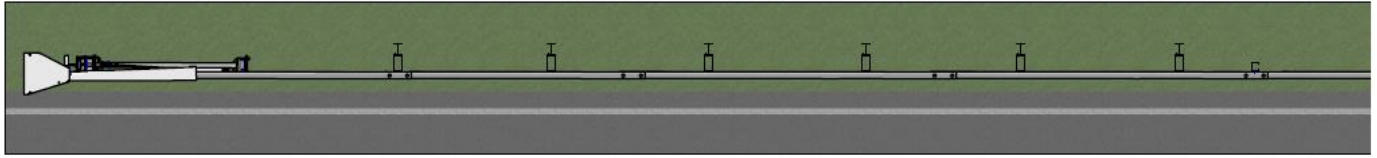

**PLAN VIEW**

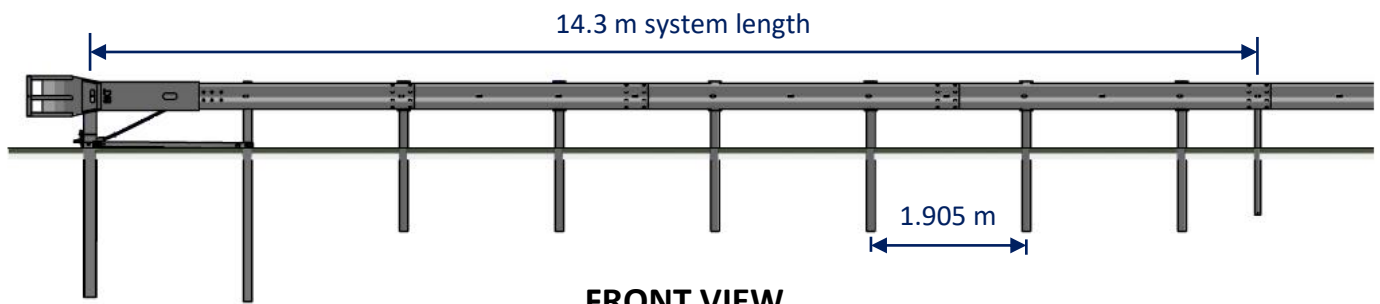

**FRONT VIEW**

### TL2 Configuration

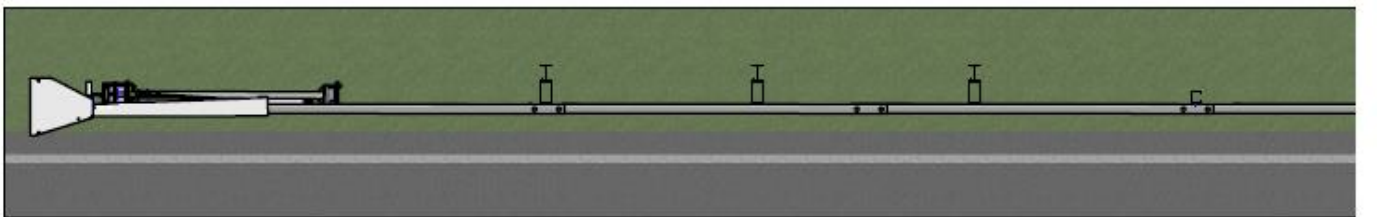

**PLAN VIEW**

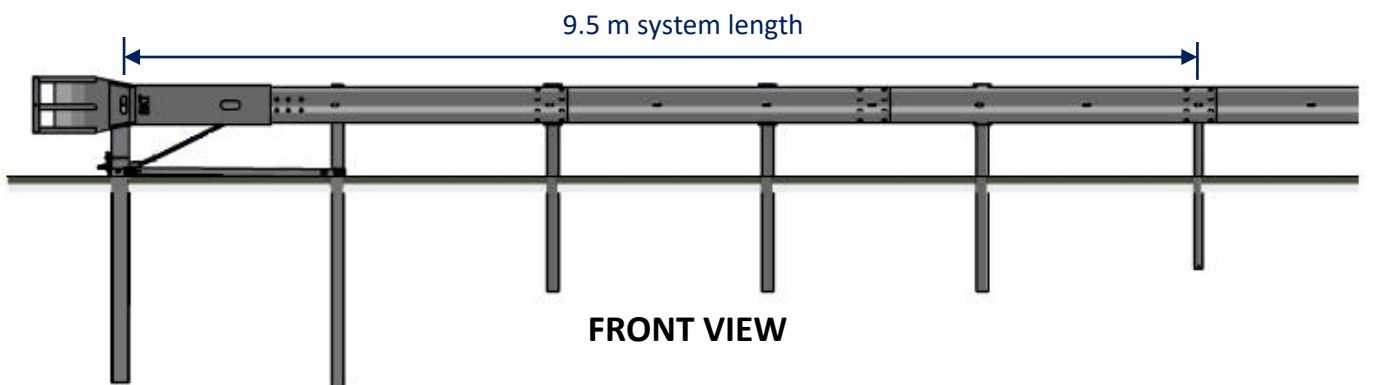

**FRONT VIEW**